

# Building Blocks

---

CPUs, Memory and Accelerators



# Reusing this material



This work is licensed under a Creative Commons Attribution-NonCommercial-ShareAlike 4.0 International License.

[http://creativecommons.org/licenses/by-nc-sa/4.0/deed.en\\_US](http://creativecommons.org/licenses/by-nc-sa/4.0/deed.en_US)

This means you are free to copy and redistribute the material and adapt and build on the material under the following terms: You must give appropriate credit, provide a link to the license and indicate if changes were made. If you adapt or build on the material you must distribute your work under the same license as the original.

Note that this presentation contains images owned by others. Please seek their permission before reusing these images.



EPSRC

NERC SCIENCE OF THE ENVIRONMENT

CRAY  
THE SUPERCOMPUTER COMPANY

| epcc |



<http://www.archer.ac.uk>  
[support@archer.ac.uk](mailto:support@archer.ac.uk)



| epcc |



# Outline

- Computer layout
  - CPU and Memory
  - What does performance depend on?
  - Limits to performance
- Silicon-level parallelism
  - Single Instruction Multiple Data (SIMD/Vector)
  - Multicore
  - Symmetric Multi-threading (SMT)
- Accelerators (GPGPU and Xeon Phi)
  - What are they good for?



# Computer Layout

How do all the bits interact and which ones matter?





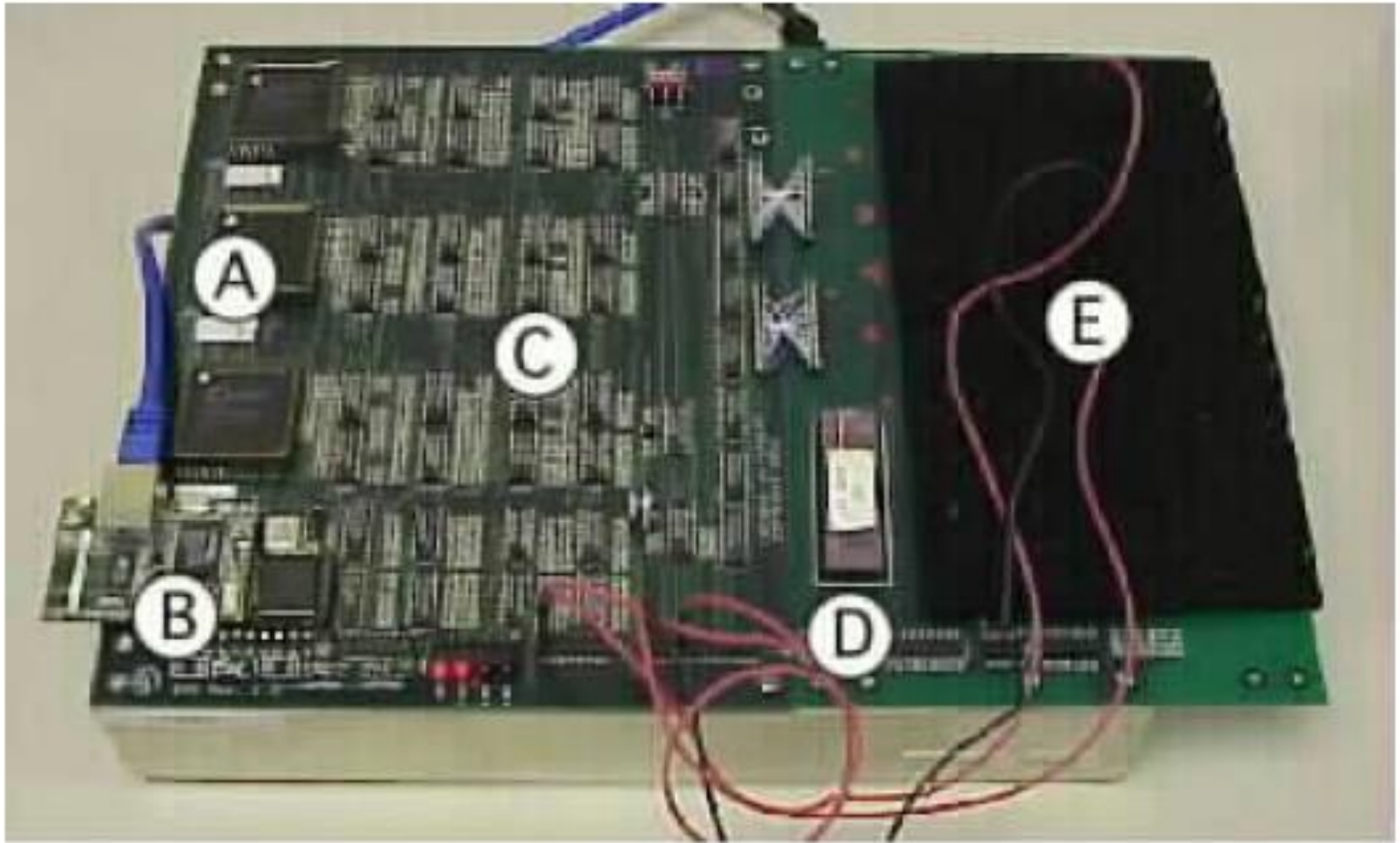

# Anatomy of a computer

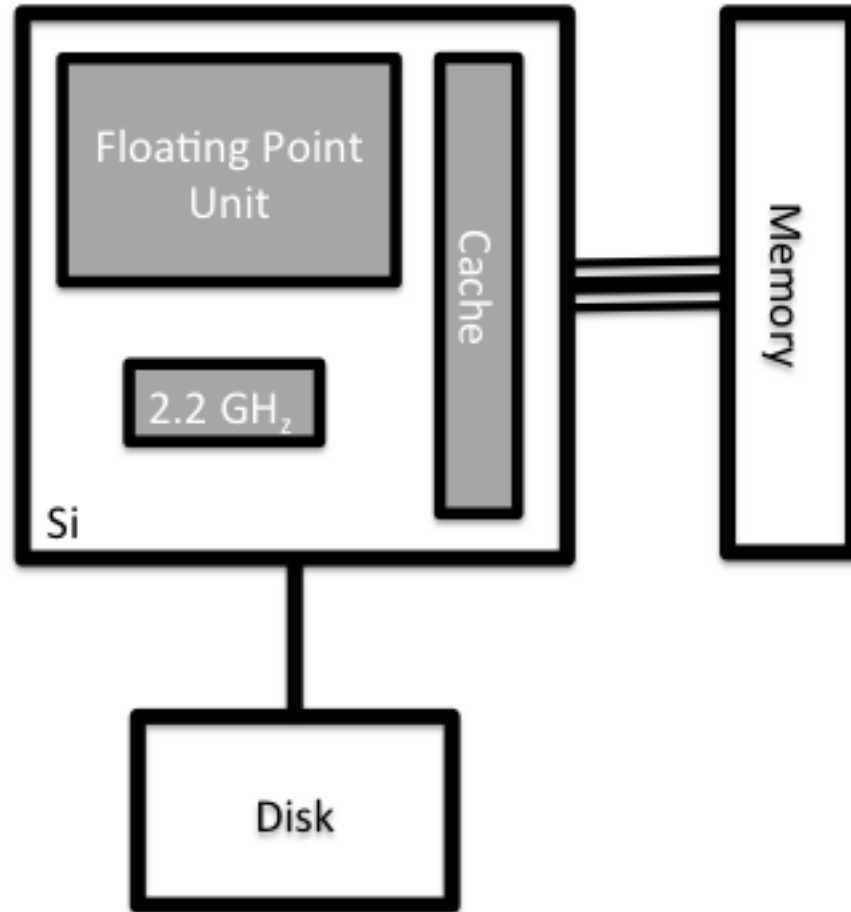



# Data Access

- Disk access is slow
  - a few hundreds of Megabytes/second
- Large memory sizes allow us to keep data in memory
  - but memory access is slow
  - a few tens of Gigabytes/second
- Store data in fast cache memory
  - cache access much faster: hundreds of Gigabytes per second
  - limited size: a few Megabytes at most

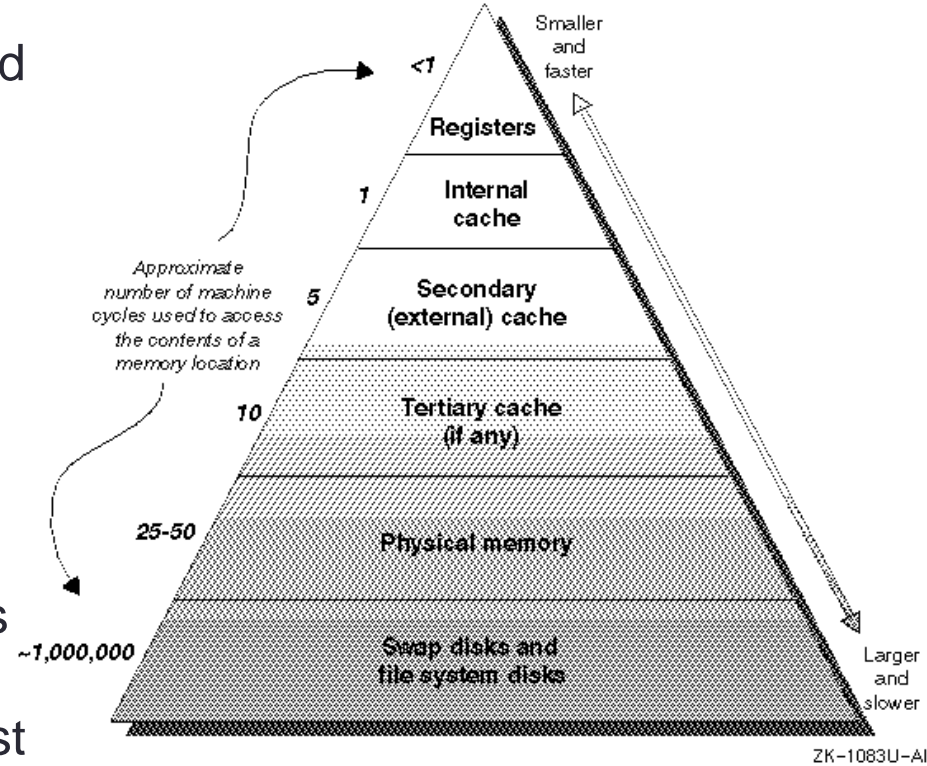

# Performance

- The performance (time to solution) on a single computer can depend on:
  - Clock speed – how fast the processor is
  - Floating point unit – how many operands can be operated on and what operations can be performed?
  - Memory latency – what is the delay in accessing the data?
  - Memory bandwidth – how fast can we stream data from memory?
  - Input/Output (IO) to storage – how quickly can we access persistent data (files)?



# Performance (cont.)

- Application performance often described as:
  - Compute bound
  - Memory bound
  - IO bound
  - (Communication bound – more on this later...)
- For computational science
  - most calculations are limited by memory bandwidth
  - processor can calculate much faster than it can access data



# Silicon-level parallelism

What does Moore's Law mean anyway?





# What to do with all those transistors?

- For over 3 decades until early 2000's
  - more complicated processors
  - bigger caches
  - faster clock speeds
- Clock rate increases as inter-transistor distances decrease
  - so performance doubled every 18-24 months
- Came to a grinding halt about a decade ago
  - reached power and heat limitations
  - who wants a laptop that runs for an hour and scorches your trousers!



# Alternative approaches

- Introduce parallelism into the processor itself
  - vector instructions
  - simultaneous multi-threading
  - multicore



# Single Instruction Multiple Data (SIMD)

- For example, vector addition:

$$\begin{array}{|c|} \hline a_0 \\ \hline a_1 \\ \hline a_2 \\ \hline a_3 \\ \hline \end{array} + \begin{array}{|c|} \hline b_0 \\ \hline b_1 \\ \hline b_2 \\ \hline b_3 \\ \hline \end{array} = \begin{array}{|c|} \hline c_0 \\ \hline c_1 \\ \hline c_2 \\ \hline c_3 \\ \hline \end{array}$$

- single instruction adds 4 numbers
- potential for 4 times the performance



# Symmetric Multi-threading (SMT)

- Some hardware supports running multiple instruction streams simultaneously on the same processor, e.g.
  - stream 1: loading data from memory
  - stream 2: multiplying two floating-point numbers together
- Known as *Symmetric Multi-threading (SMT)* or *hyperthreading*
- Threading in this case can be a misnomer as it can refer to processes as well as threads
  - These are hardware threads, not software threads.
  - Intel Xeon supports 2-way SMT
  - IBM BlueGene/Q 4-way SMT



# Multicore

- Twice the number of transistors gives 2 choices
  - a new more complicated processor with twice the clock speed
  - two versions of the old processor with the same clock speed
- The second option is more power efficient
  - and now the only option as we have reached heat/power limits
- Effectively two independent processors
  - ... except they can share cache
  - commonly called “cores”



# Multicore

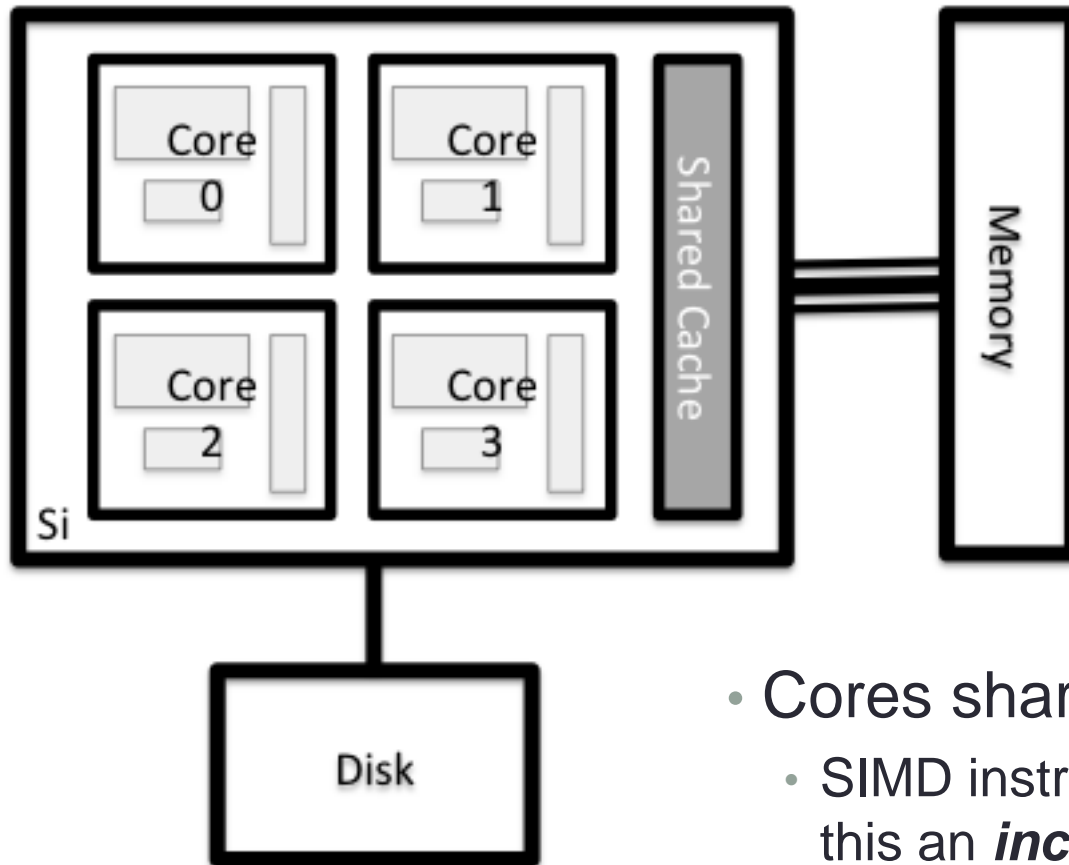

- Cores share path to memory
  - SIMD instructions + multicore make this an *increasing* bottleneck!

# Intel Xeon E5-2600 – 8 cores HT

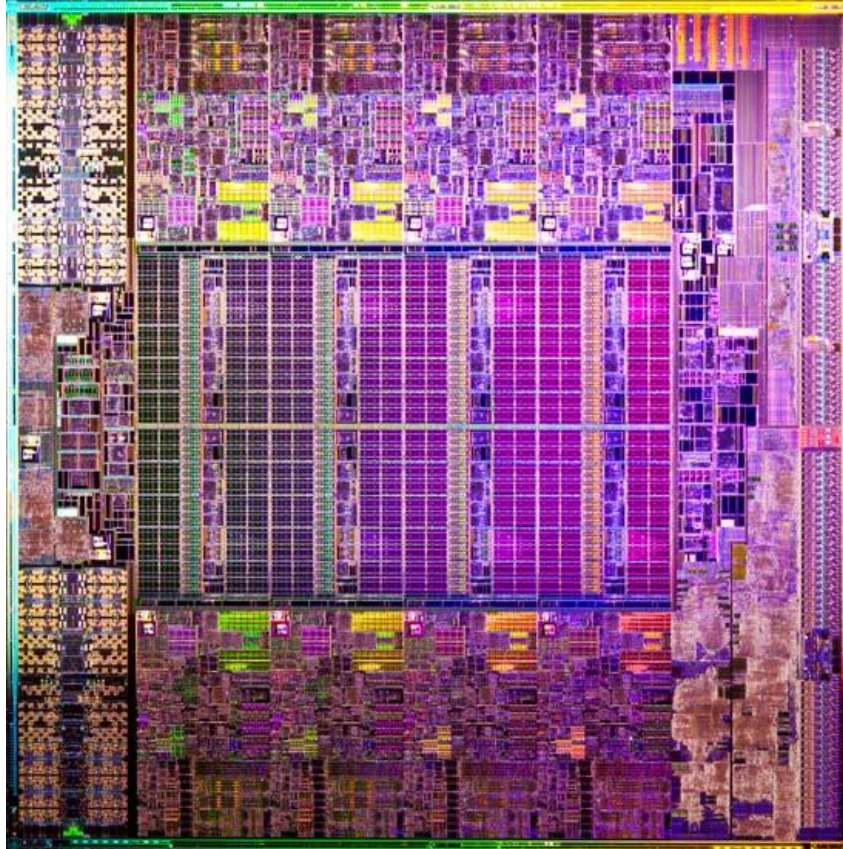

# What is a processor?

- To a programmer
  - the thing that runs my program
  - i.e. a single core of a multicore processor
- To a hardware person
  - the thing you plug in to a socket on the motherboard
  - i.e. an entire multicore processor
- Some ambiguity
  - in this course we will talk about cores and sockets
  - try and avoid using “processor”

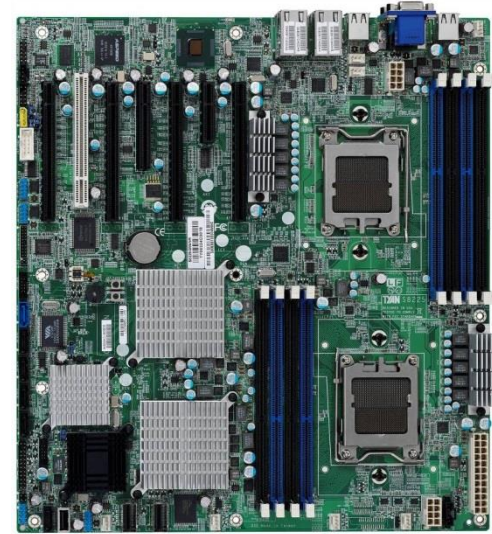

# Chip types and manufacturers

- x86 – Intel and AMD
  - “PC” commodity processors, SIMD (SSE, AVX) FPU, multicore, SMT (Intel); Intel currently dominates the HPC space.
- Power – IBM
  - Used in high-end HPC, high clock speed (direct water cooled), SIMD FPU, multicore, SMT; not widespread anymore.
- PowerPC – IBM BlueGene
  - Low clock speed, SIMD FPU, multicore, high level of SMT.
- SPARC – Fujitsu
- ARM – Lots of manufacturers
  - Not yet relevant to HPC (weak FP Unit)



# Accelerators

Go-faster stripes



# Anatomy

- An *Accelerator* is an additional resource that can be used to off-load heavy floating-point calculation
  - additional processing engine attached to the standard processor
  - has its own floating point units and memory

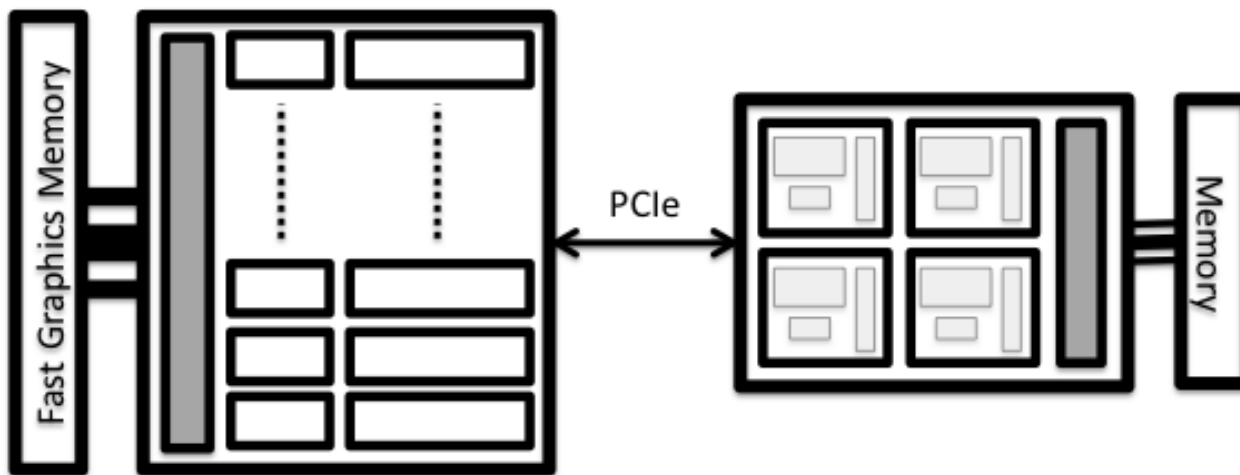



# AMD 12-core CPU

- Not much space on CPU is dedicated to computation

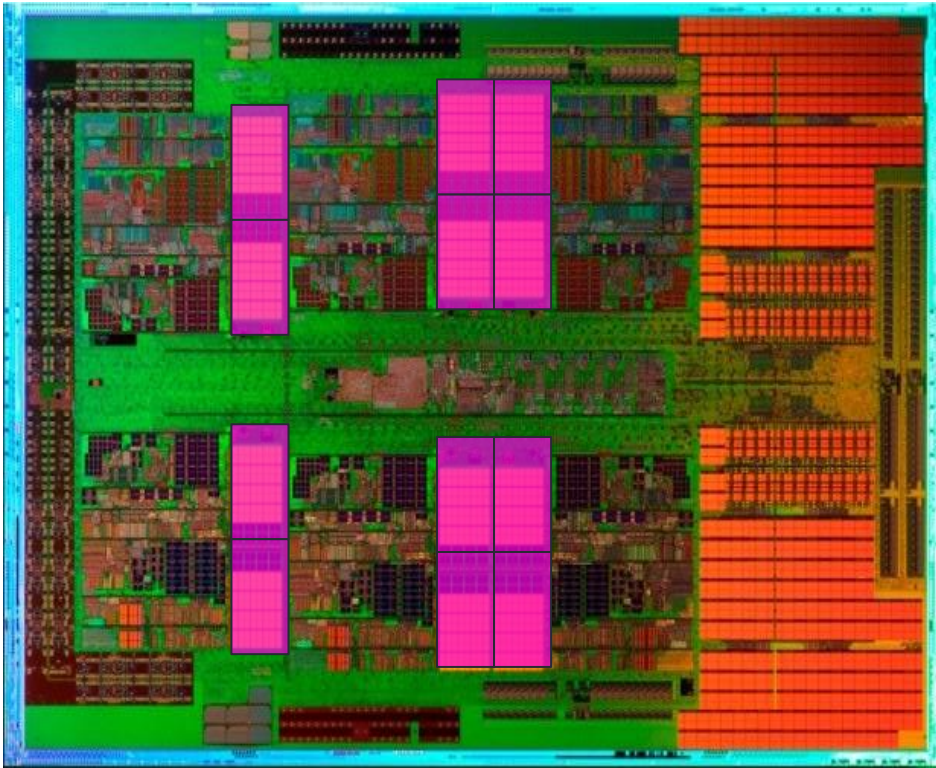

 = compute unit  
(= core)

# NVIDIA Fermi GPU

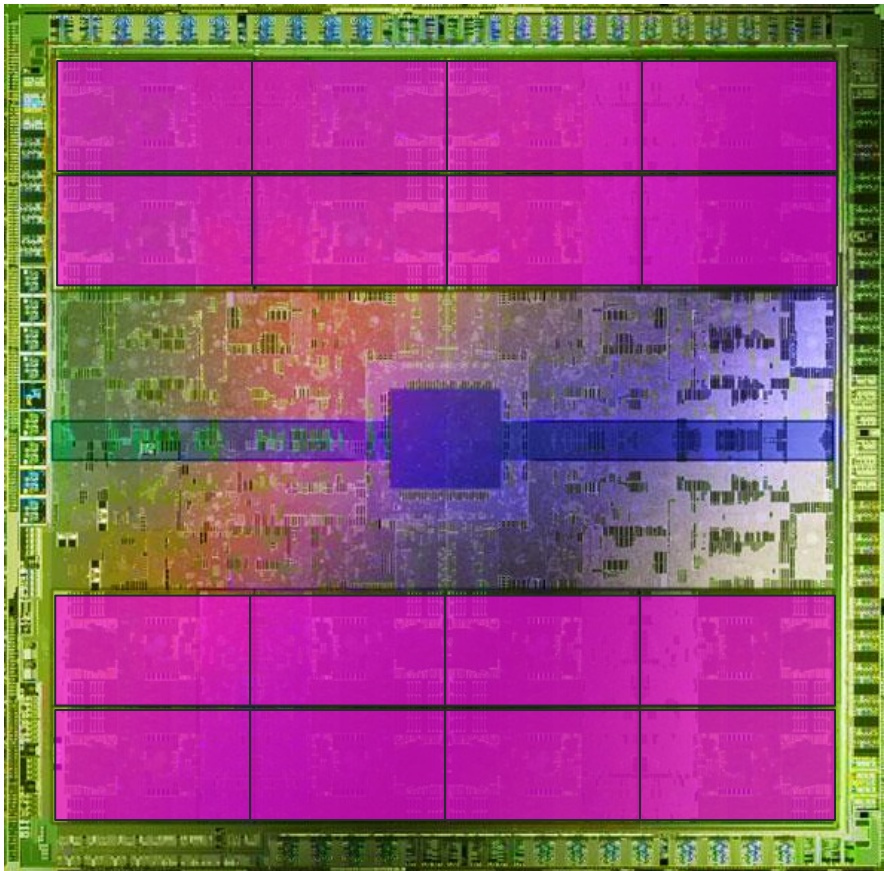



- GPU dedicates much more space to computation
  - At expense of caches, controllers, sophistication etc

 = compute unit  
(= SM  
= 32 CUDA cores)

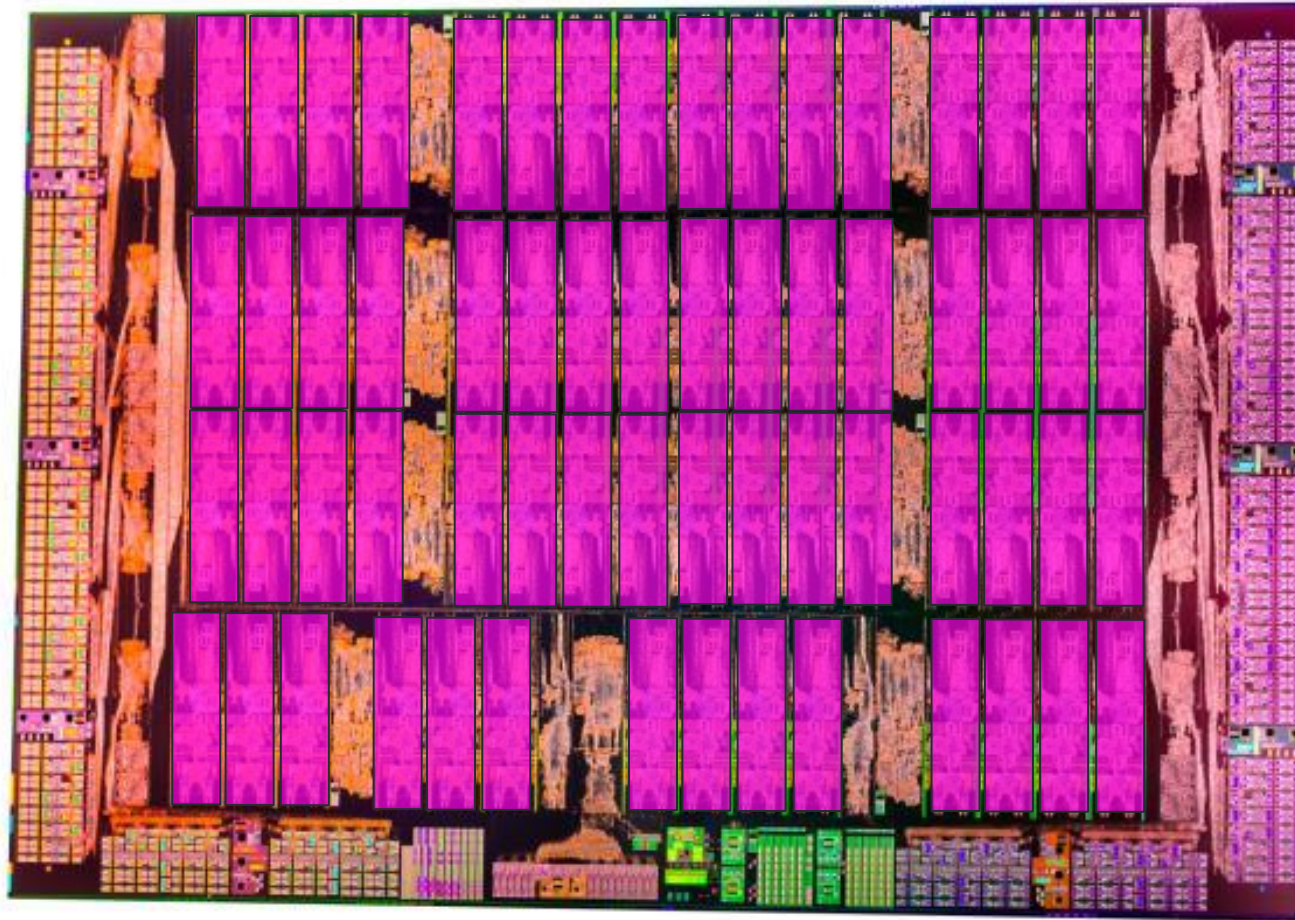

# Intel Xeon Phi – KNC (Knights Corner)



 = compute unit  
(= core)

# Intel Xeon Phi – KNL (Knights Landing)

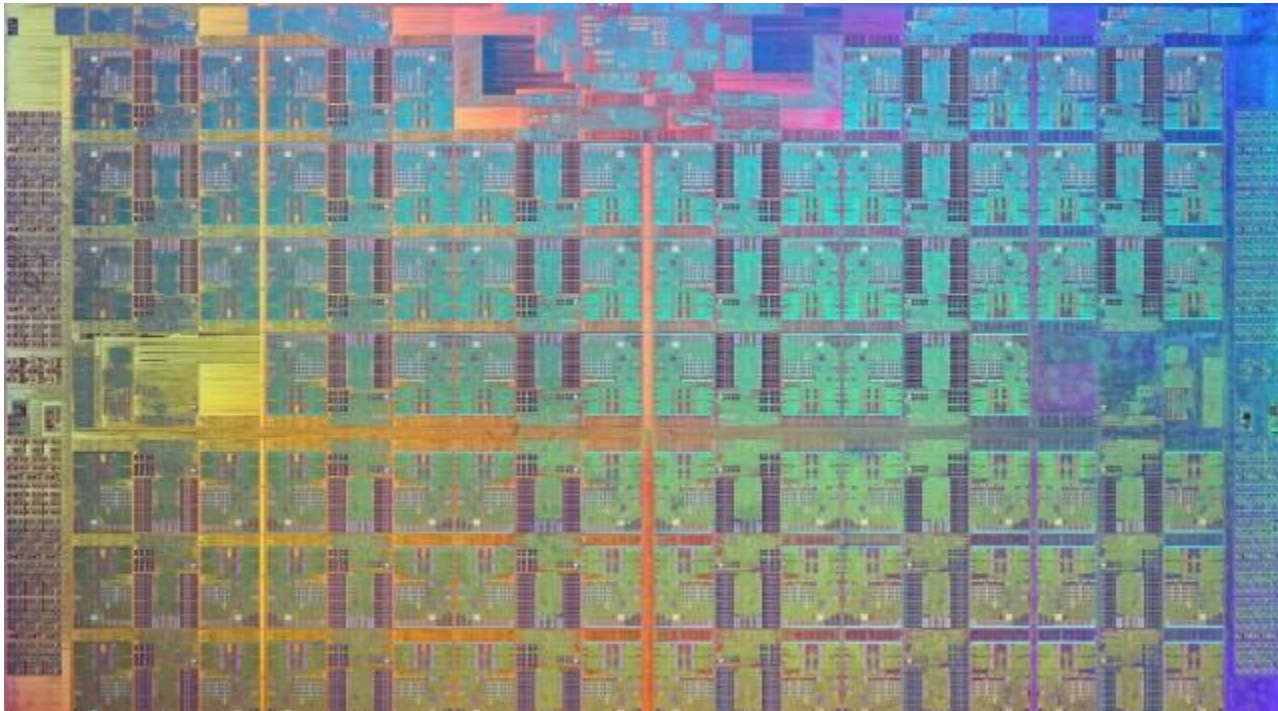

# Memory

- For most HPC applications, performance is very sensitive to memory bandwidth
- GPUs and Intel Phi both use Graphics memory: much higher bandwidth than standard CPU memory
- KNL has high bandwidth on-board memory

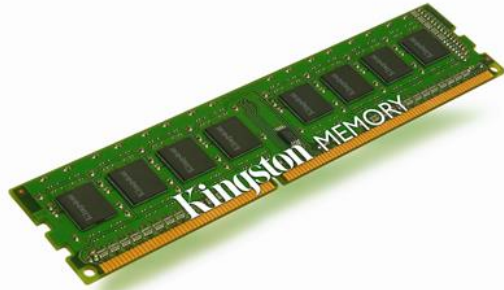

CPUs use DRAM



GPUs and Xeon Phi use Graphics DRAM

# Summary - What is automatic?

- Which features are managed by hardware/software and which does the user/programmer control?
  - Cache and memory – automatically managed
  - SIMD/Vector parallelism – automatically produced by compiler
  - SMT – automatically managed by operating system
  - Multicore parallelism – manually specified by the user
  - Use of accelerators – manually specified by the user

